

INSTALLATION INSTRUCTIONS: Trilite Ultra & Safelight Energysaver FAIR

Trilite Ultra 36 - Trilite Ultra 45 - Safelight Energysaver FAIRs (all U-values variants)

Page 1 of 3

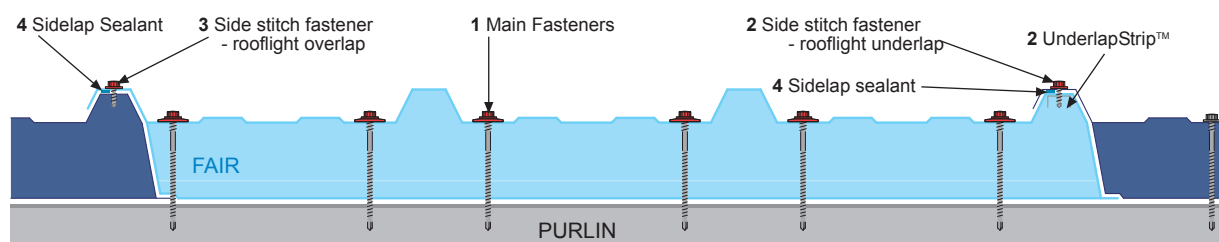

Cross Section: Heavyweight FAIR (Factory Assembled Insulating Rooflight)

- 1 MAIN FASTENERS**
 5.5mm diameter fasteners fitted with minimum 19mm diameter washers with soft (40 shore hardness) bonded seal, typically poppy red colour. Do not over tighten fixings. There should be at least five main fixings per purlin, fitted in the trough, max 250mm apart. For profiles where pitch between corrugations is over 200mm, there should be two fixings per trough, with the fixings located either side of each main corrugation. *See below for typical references
- 2 SIDE STITCH FASTENER - ROOFLIGHT UNDERLAP**
 Underlap Strip™ is bonded into the underlapping sidelap : a single continuous length, profiled to match the corrugation to give added rigidity and ensure standard stitching screws can be reliably secured. This reduces the cost of fasteners and the number of fastener types on site, and improves ease of installation. Standard stitching screws should then be fitted at approx. 600mm centres (Note: stitching screws need to be evenly spaced about any FAIR endlap and not fixed through the joint). Fasteners should typically be poppy red colour. * See below for typical references
- 3 SIDE STITCH FASTENER - ROOFLIGHT OVERLAP**
 Side stitch at approx. 600mm centres using standard stitching screws. (Note: stitching screws need to be evenly spaced about any FAIR endlap and not fixed through the joint). Fasteners should typically be poppy red colour. * See below for typical references
- 4 SIDELAP SEALANT**
 Single strip (6x5mm section) of UV stable pale coloured cross linked butyl mastic (BMS: Class A) - positioned on the crown of the sheet just outside the line of sidelap fasteners. Immediately downslope of the endlap, it is necessary to have at least a 5mm thick sidelap sealant for a distance of 150mm on the side where the outer sheet underlaps adjacent sheets. The same applies for the sidelap sealant immediately upslope of the endlap on the side where the outer sheet overlaps the adjacent panels (see page 3).
- 5 ENDLAP SEALANT**
 All endlaps should be sealed with 2 beads of 8mm diameter round section, UV stable, pale coloured cross linked butyl mastic (BMS: Class A). These should be positioned above and below the line of fixing, no more than 25mm from the line of fasteners. If a seal is required at the tail of the lap, gun applied silicon (ISO11600-F-25LM) should be used.
- The top end of every FAIR must be seated onto the purlin (or extension bracket) by at least 60mm after allowing for on site tolerances.
- This ensures full support for the internal reinforcement and maintains non-fragile classification. It is possible for standard purlins to provide sufficient support to both FAIR and composite panel if lap position and steelwork are correctly aligned. However, steelwork tolerances can cause on-site variations from nominal position. Extension brackets will be necessary to provide correct support if the alignment of lap and purlin varies by more than 5mm.
- Brett Martin Daylight Systems FAIRs incorporate unique Hardpak rigid internal reinforcement at each purlin position; it is essential that these are located directly over the purlin (or on extension brackets) at the top and at each intermediate position, so that the main fastener locates with the purlin. Full details are given in TECHNICAL BULLETIN 139.

*	Stainless Steel	Carbon Steel
Main Fasteners	SFS SXCP5-S19-5.5xlength or EJOT CF19-JT3-D-6H-5.5xlength	SFS SDT5-S19-5.5xlength or EJOT CF19-LSHT-5.5xlength
Underlap Side Stitch (with ULS) & Overlap Side Stich	SFS SXP3/12-S16-6x35 or EJOT CF15-JT3-2H-5.5x30	SFS SDL3-T15-5.5x25 or EJOT CF15-SF-6.3x25

Correct installation of rooflights is important to ensure they achieve the correct level of safety performance, and give long term weather tightness.

ENDLAP - COMPOSITE OVER FAIR

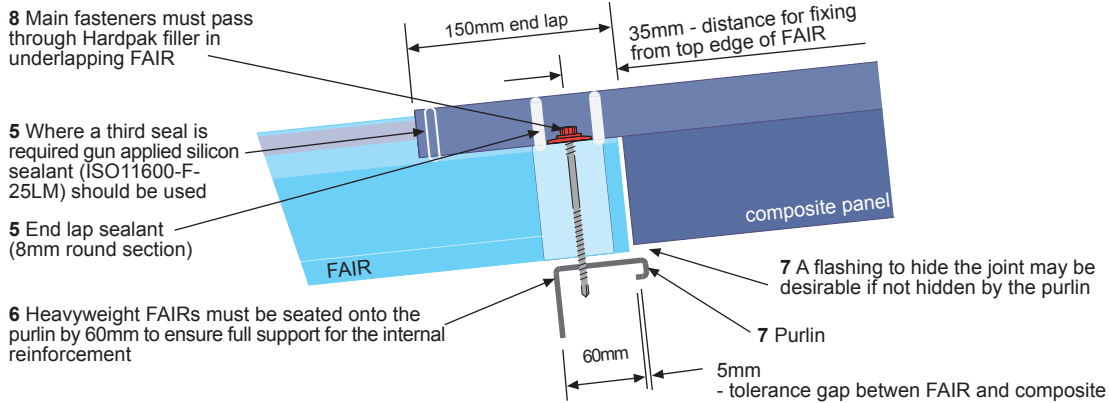

ENDLAP - FAIR OVER COMPOSITE

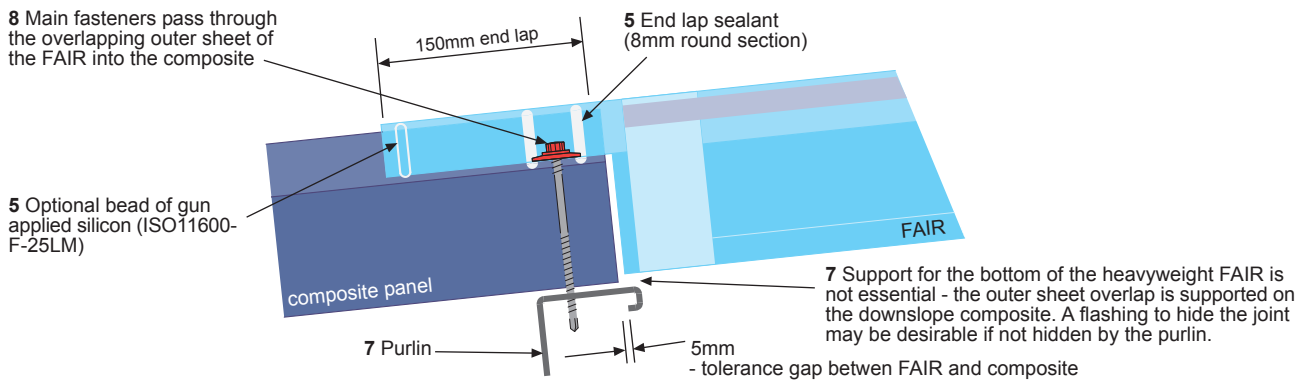

ENDLAP - FAIR OVER FAIR

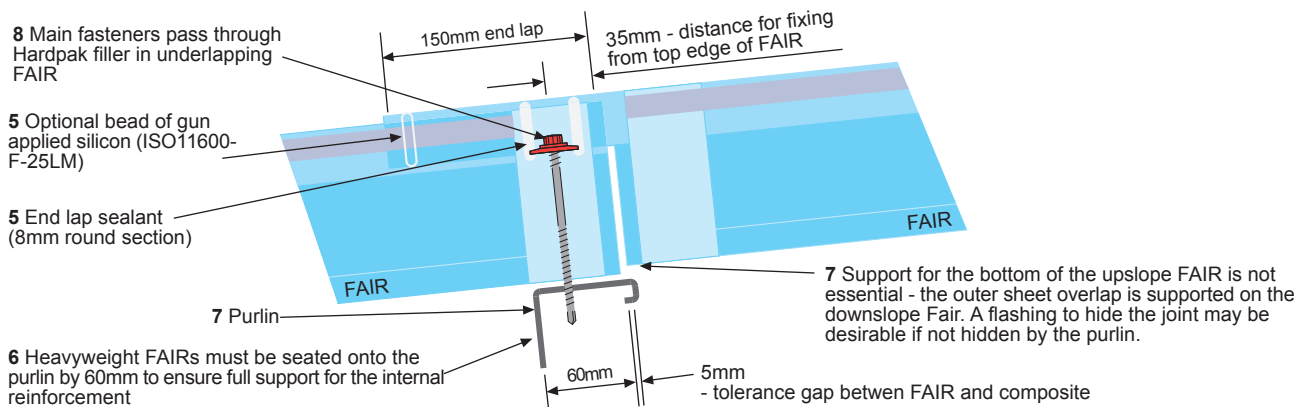

MID SPAN ARRANGEMENT

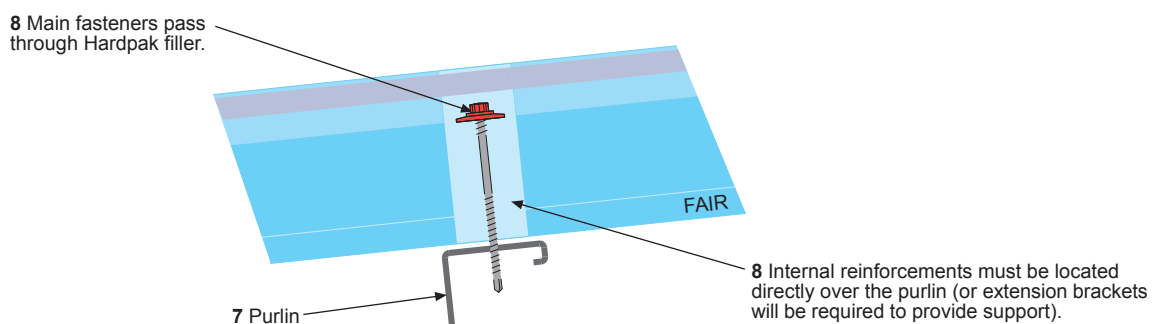

SIDLAP SEALING AT END LAPS

At all 3 & 4 way joints, sealant is required between all lapping components to ensure a weather tight seal. This necessitates an additional bead of sealant at endlaps; when using heavyweight FAIRs it is recommended that this additional bead is extended as shown.

SIDLAP SEALING AT OVERLAP SIDE (at top of any FAIR)

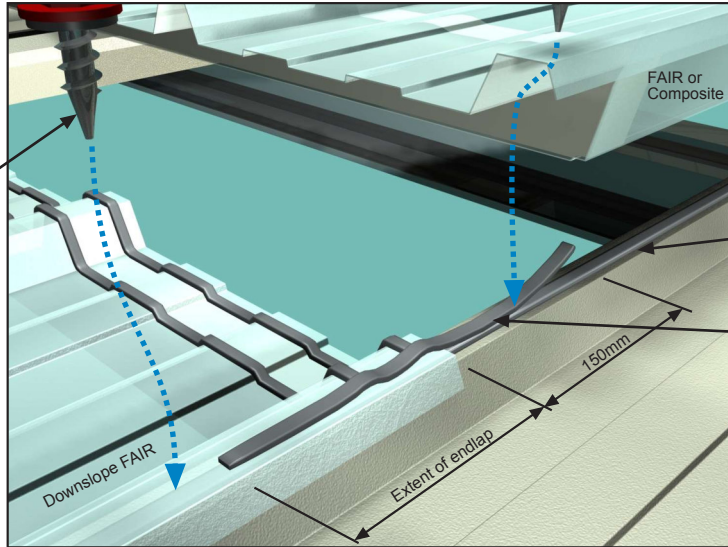

2/3 Note: when stitching the side lap it is important to have the stitching screws evenly spaced about any FAIR endlap (min 150mm from centre of lap) and not fixed through the joint.

- 4 Continuous strip of side lap sealant (6x5mm mastic)
- 4 Additional sidelap sealant for length of lap and extending 150mm upslope of endlap.

SIDLAP SEALING AT UNDERLAP SIDE (at bottom of any FAIR)

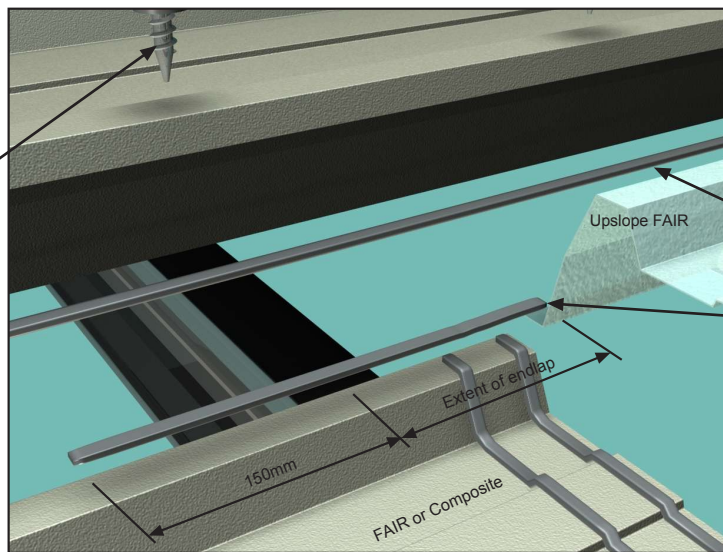

2/3 Note: when stitching the side lap it is important to have the stitching screws evenly spaced about any FAIR endlap (min 150mm from centre of lap) and not fixed through the joint.

- 4 Continuous strip of side lap sealant (6x5mm mastic)
- 4 Additional sidelap sealant for length of lap and extending 150mm downslope of endlap.

CORRECT HANDLING OF FAIRS IS CRITICAL - FULL GUIDANCE IS GIVEN IN TECHNICAL BULLETIN 154 ALL RECOMMENDATIONS MUST BE FOLLOWED IN FULL

Minimum Design Roof Pitch 5.5° / Finished Roof Pitch 4°

BS5427, the British Standard "Code of practice for the use of profiled sheet for roof and wall cladding on buildings" recommends a minimum finished roof pitch of at least 4°, with a minimum design pitch of 5.5° to allow for tolerances and onsite variations, when using any profiled roofing systems with either through fixings or endlaps (see BS5427:2016 section 5.1.3). We recommend that all Trilite in-plane rooflights should be installed in accordance with these BS5427 recommendations. If Trilite sheets are fitted at lower than 4° finished roof pitch, there will not be any detrimental effect on the rooflight sheet itself, but the risk increases of small variations in installation details causing leaks at endlaps or fixings, as detailed in BS5427 (see Note 3 to 5.1.3). Trilite Ultra rooflights are more rigid, providing more even compression of sealants and less localised deflection around fasteners, thus reducing risk of leaks at endlaps or fixings and should be considered for use on applications near BS5427 minimum pitch recommendations.



Daylight Systems



Alderman's Green Ind Est Coventry CV2 2QU Tel: 024 7660 2022 daylight@brettmartin.com www.daylightsystems.com

The manufacturer operates a policy of continuous product improvement, and reserves the right to alter specifications at any time without notice. Every effort has been taken to ensure all details contained in this document are correct at the time of going to press but this document should be used only as a guide and does not in any way form part of a contract or warranty. It is the customer's responsibility to ensure that the product is suitable for the actual conditions of use, which are beyond the control of the manufacturer.